

# BEST WAITING (U LEG)

Technical Data Sheet





## BEST WAITING (U LEG)

Designer: Z Design Team

Best is the combination of all best features that an office chair must have. This office chair that can be made with mobile or fixed leg for different purposes can optionally be equipped with an armrest. Being the modern and coherent picture with metal legs and fabric upholstery, Best falls with any space thanks to its ideal dimensions.

### DESCRIPTIONS

---

#### METAL STRUCTURE

It is made of Q25 mm DKP profile tube with a wall thickness of 1,5 mm, formed in special moulds by CNC bending. On the surface of metal leg, electrostatic oven coating or heat-treated chrome plating is used to give resistance to oxidizing and corrosion.

#### UPHOLSTERY

It is made of a monoblock body with fabric or artificial leather upholstery on polyurethane bulk sponge of 55-60 kg/m<sup>3</sup> formed in special moulds. 5 mm and 10 mm transmission rod and metal sheet bars of 20x5mm and 20x3 mm are used in polyurethane inner metal frame.

#### ARMREST

Arm resting part is made of hard polypropylene plastic and click-fitted in CNC-bended leg.

#### ACCESSORY

Plugged-in nail chair feet made of hard polypropylene plastic are used in the floor contacting parts of the legs.

#### AREA OF USE

Best Guest U Leg is designed for offices, hospitals, schools and new workspaces.

#### DESIGNER / COLLECTION

Best Guest U Leg was designed by Z Design Team. It was designed for 2022/2023 collection.

#### MATERIAL LIBRARY

You can access Zivella's library of wood, metal, fabric and artificial leather with the QR code below.



Material Library





## BEST WAITING (U LEG)

### MEASUREMENTS

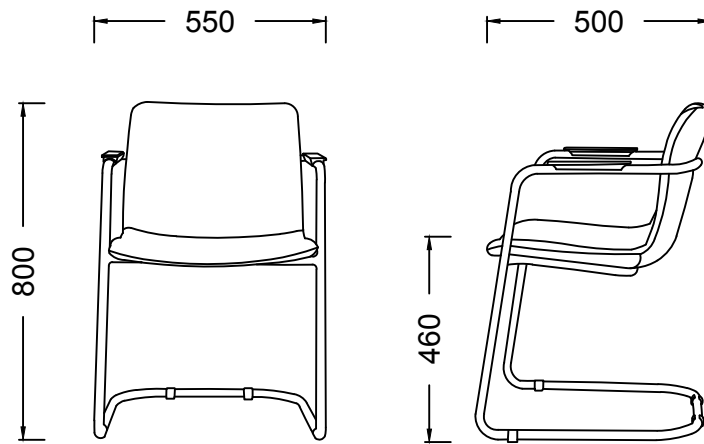

BRK225 - BEST WAITING U LEG STATIC  
BRK225K - BEST WAITING U LEG CHROME

### Parcel Measurements

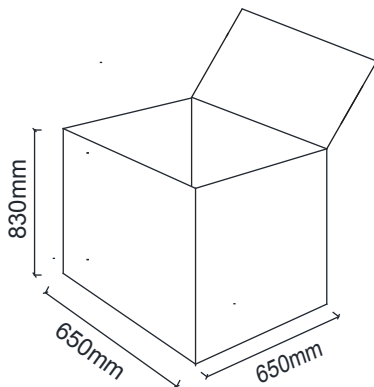

Unit of measurement is millimeters.