

BEAM BANK

Technical Data Sheet





BEAM BANK

Designer: Oğuzhan Abdik

Beam is a sculptural bench that highlights the purest form of solid wood. Produced with different varnish and leather color options, Beam brings warmth to its surroundings and symbolizes sincerity in communication.

EXPLANATIONS

WOODEN STRUCTURE

The entire wooden frame is made from first-grade kiln-dried solid ash wood.

On the wooden surface, to protect against external factors and ensure long-lasting use, 3 layers of polyurethane filler varnish are applied, followed by 2 layers of polyurethane matte varnish.

UPHOLSTERY

For the bench seating, an 8 mm thick panel material is used, covered with 28 kg/m³ density, 1 cm thick gray foam, which is resistant to localized sagging and maintains its natural structure.

ACCESSORIES

Feet: The feet are equipped with nail caps made from hard polypropylene plastic, placed where they make contact with the floor.

USAGE AREA

Beam Bank is designed for offices, hospitals, schools, and new workspaces.

DESIGNER / COLLECTION

Beam Bank was designed by Oğuzhan Abdik for the 2022/2023 collection.

MATERIAL LIBRARY

Zivella; you can access the wood, metal, fabric, and faux leather library using the QR code below.



Material Catalog



BEAM BANK

DIMENSIONS

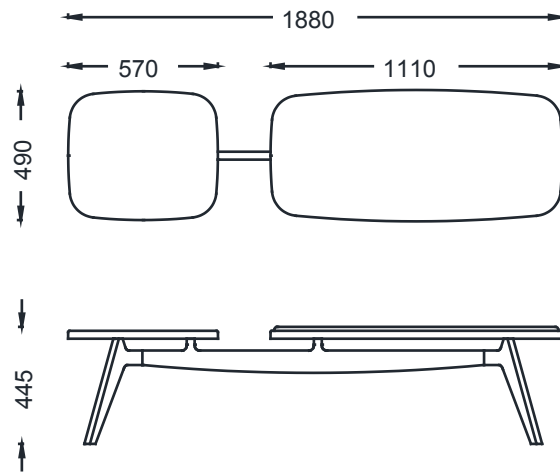

BRK2700 - BEAM BANK

Packaging Dimensions

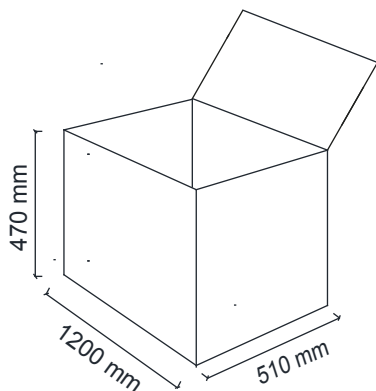

Measurements are in millimeters.