

# BEST GUEST

Technical Data Sheet





## BEST GUEST

Designer: Z Design Team

Best is the embodiment of the finest features that an office chair is expected to include. Provided with moving or fixed legs for different purposes, optional arm rests can also be added to this office chair. Giving a modern and harmonious feeling with its metal legs and fabric upholstery, Best adapts to every space perfectly with its ideal size.

### DESCRIPTIONS

#### METAL STRUCTURE

Metal Leg: Manufactured by CNC bending from DKP Profile pipe shaped in special molds with a diameter of Q25mm and a wall thickness of 1.5mm. Used with 90 micron thick textured electrostatic powder oven paint on the metal leg surface.

#### UPHOLSTERY

Manufactured from a monoblock body upholstered in fabric or artificial leather on 55-60 kg / m<sup>3</sup> density polyurethane cast sponge formed in special molds. 5mm and 10mm transmission shaft and 20x5mm, 20x3mm sized metal slats are used in the polyurethane inner metal skeleton.

#### ARMREST

The armrest part is made of hard polypropylene plastic material, it is connected to the CNC bending foot with the fitting system.

#### ACCESSORY

Wheel: 50mm diameter wheels made of hard plastic material, swivel in all directions with 11mm rings.

#### AREA OF USE

Best Guest is designed for offices, hospitals, schools and new workspaces.

#### DESIGNER / COLLECTION

Best Guest was designed by Z Design Team. It was designed for 2022/2023 collection.

#### MATERIAL LIBRARY

You can access Zivella's library of wood, metal, fabric and artificial leather with the QR code below.



Material Library





## BEST GUEST

### MEASUREMENTS

---

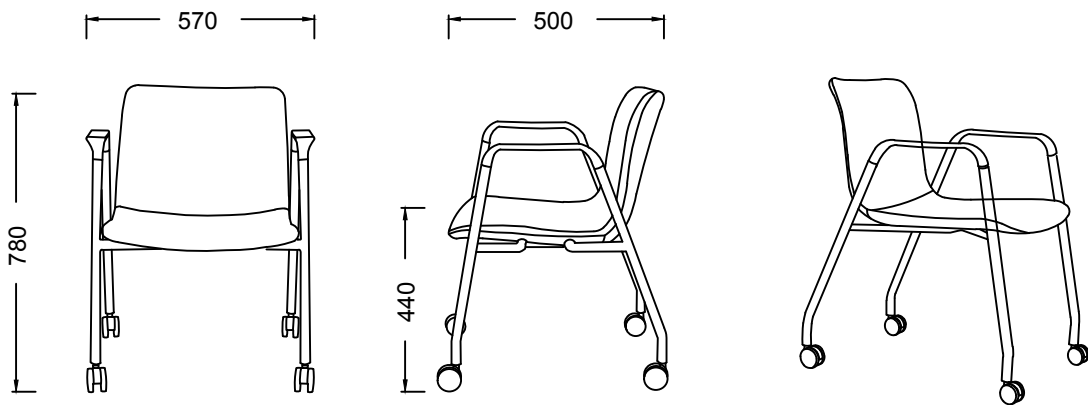

BRK220 - Best Guest (Wheeled Leg with Armrest)

### Parcel Measurements

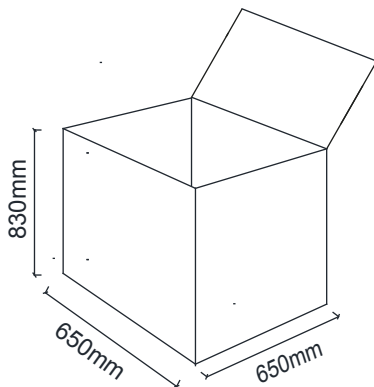

Unit of measurement is millimeters.