

LOFT HIGH MEETING TABLE

Technical Data Sheet





LOFT HIGH MEETING TABLE

Designer: Alp Nuhođlu

With its simple and sturdy design, the Loft High Meeting Table adds dynamism to your workspace, offering new solutions for modern working environments with its height metal legs, series-specific separators, and various color options.

DESCRIPTION

STRUCTURE

The product's metal structure is made from Q40 mm diameter, 2 mm thick tube legs and 40x20x1.5 mm metal profile supports. The legs and supports are packaged in a demountable manner, and the connections are made using bolt connection elements.

TABLETOP

The tabletop is made from 18 mm thick particle board with melamine coating on both sides, and all four edges are covered with 1 mm thick impact-resistant PVC edge banding.

UPHOLSTERY

The LFS100 Loft Separator is made from 18 mm thick particle board, laminated with 10 mm foam and fabric upholstery.

ACCESSORIES

Height plastic bingo feet are used on the legs. Metal L-shaped connection elements are used to attach the legs to the table.

USAGE AREA

The Loft High Meeting Table is designed for workspaces such as meeting rooms.

DESIGNER / COLLECTION

The Loft High Meeting Group was designed by Alp Nuhođlu for the 2022/2023 collection.

MATERIAL LIBRARY

Zivella; you can access the wood, metal, fabric, and faux leather library using the QR code below.



Material Catalog



LOFT HIGH MEETING TABLE

DIMENSIONS

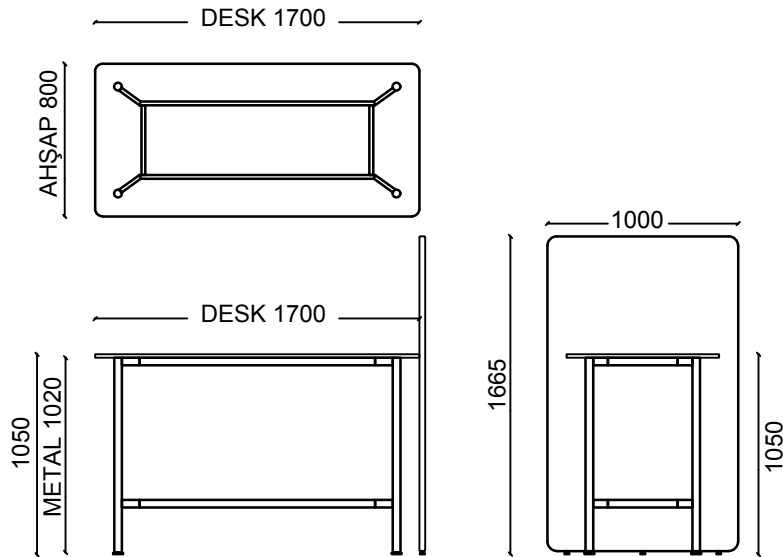

LFM80170 - LOFT HIGH MEETING TABLE
LFS100 - LOFT SEPERATOR

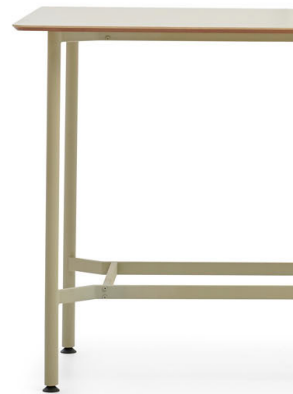

Measurements are in millimeters.