

# WELL'S

Technical Data Sheet





## WELL'S ARMCHAIR

Designer: Emre Öner

A product was designed to make you feel the warmth of wood, bright interiors and well-being inspired by Scandinavian design styles. While making you feel the simplicity with simple lines, it is aimed to create an ergonomic and comfortable form with its curvilinear backrest structure. It is based on the philosophy of sustainability with the use of organic and natural materials in the product.

### DESCRIPTIONS

---

#### FRAME

The seat and headrest frame is made of 2nd class kiln-dried beech wood. Headrest and seat/back frames are manufactured and assembled separately.

#### WOODEN STRUCTURE

It is produced with wooden bases, 40 mm diameter lathe and solid record logs.

The wooden base is made of 1st class kiln-dried Ash solid wood. Double coat polyurethane finish with flat varnish or lacquered paint on top of triple coat of polyurethane filling varnish are applied on the wooden surface to provide protection against external factors and for enhancing durability.

#### ACCESSORY

On the surface of the product in contact with the ground, felt nail glides made of plastic material are used.

#### AREA OF USE

Well's Group can be used in indoor office lobbies, executive rooms and, if desired, at homes.

In addition to the use of single color fabric, the seat and the headrest are suitable for the use of different colors. The product range can adapt to fun and concept works in interior projects.

#### DESIGNER / COLLECTION

Well's Armchair was designed by Emre Öner.  
It was designed for 2022 / 2023 collection.

#### MATERIAL LIBRARY

You can access the wood, metal, fabric and artificial leather library with the following QR code.



Material Library



## WELL'S ARMCHAIR

### MEASUREMENTS

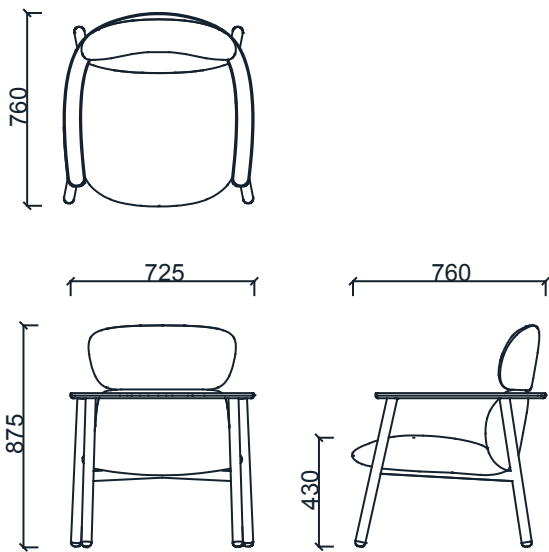

BRK2070 - WELL'S

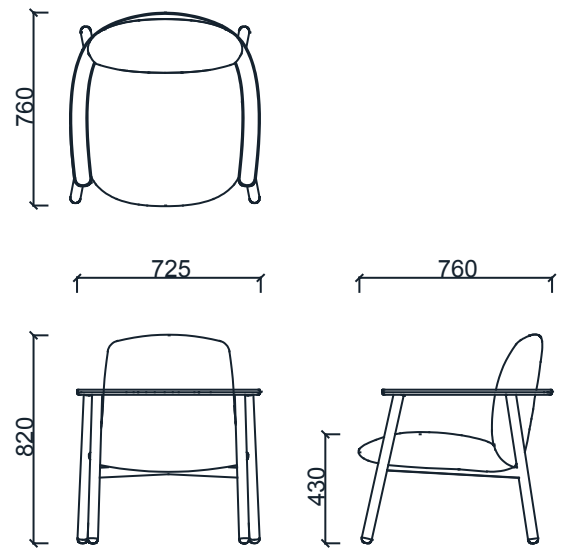

BRK2071 - WELL'S LOUNGE

### Parcel Measurements

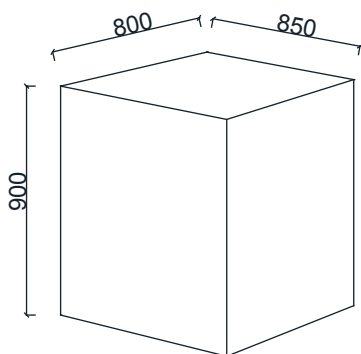

Unit of measurement is millimeters.