

LINE CONSOLE CABINET

Technical Data Sheet





LINE CONSOLE CABINET

Designer: Z Design Team

Zivella's Storage Systems are designed for use in operational, managerial, and shared spaces. With their elegant design and functionality, they meet many needs simultaneously. Their perfectly integrated structures allow office cabinets to also serve as partition panels.

EXPLANATIONS

STRUCTURE

The cabinet bodies are made from E1 quality, 18 mm thick melamine-coated particle board on both sides.

The edges of the cabinet components are protected with 1 mm thick impact-resistant PVC edging.

The back panels of the file cabinets are made from 18 mm thick, double-sided melamine-coated particle board, ensuring that the cabinet remains square and provides visual symmetry with the doors.

CONNECTIONS AND ACCESSORIES

The connections are made using M68 mm diameter, 10 mm minifix metal connection mechanisms and 832 mm plastic dowels.

Hinges: Each door has one first-quality internal spring hinge, with one featuring a soft-closing mechanism, produced by HAFELE.

Feet: The cabinet has height-adjustable plastic feet, sized Q5 cm with a height of 5 cm, produced via injection molding.

Handles: The handles are made from 128 mm electrostatically painted aluminum, produced via injection molding in special molds.

Hanger: Inside the cabinet, a Q25 mm diameter chrome hanger rod is used.

USAGE AREA

The Line Console Group is designed for use in hotels, gyms, factories, workshops, sports complexes, open offices, and executive rooms.

DESIGNER / COLLECTION

The Line Console Group was designed by Z Design Team for the 2019/2020 collection.

MATERIAL LIBRARY

Zivella; you can access the wood, metal, fabric, and faux leather library using the QR code below.



Material Catalog



LINE CONSOLE CABINET

DIMENSIONS

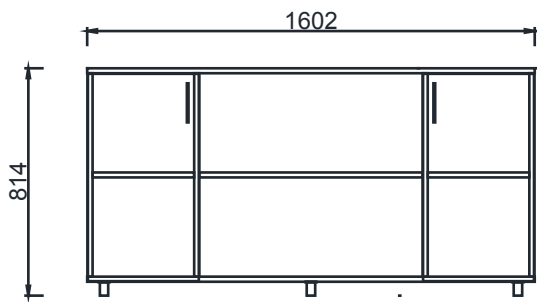

BRD16081 - LINE 16080

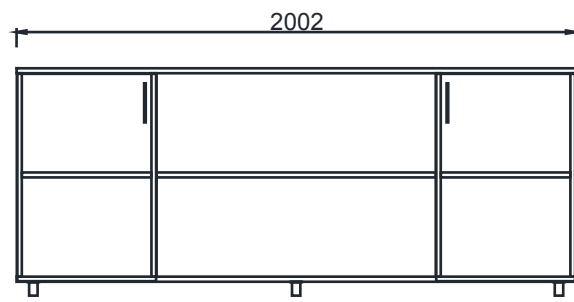

BRD20081 - LINE 20080

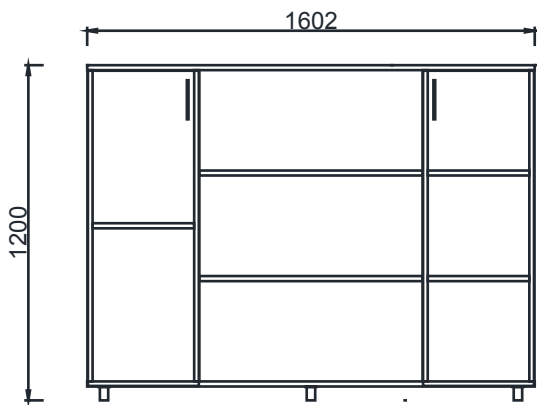
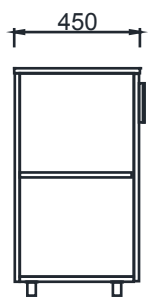

BRD160121 - LINE 160120

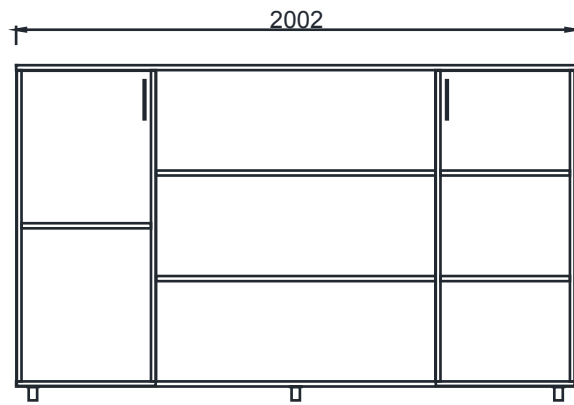

BRD200121 - LINE 200120

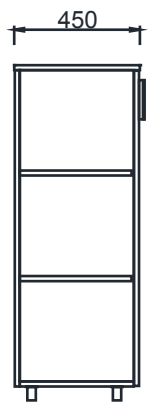

Measurements are in millimeters.