

STOR FULL-COVERED CABINET

Technical Data Sheet





STOR FULL-COVERED CABINET

Designer: Z Design Team

Zivella's Storage Systems, used in operational, managerial, and shared spaces, stand out with their elegance while offering functionality that meets various needs simultaneously. Their perfectly integrated structures allow office cabinets to also serve as partition panels.

EXPLANATIONS

STRUCTURE

The cabinet bodies are made from E1 quality, 18 mm thick melamine-coated particle board on both sides.

The edges of the cabinet components are protected with 1 mm thick impact-resistant PVC edging.

The back panels of the file cabinets are made from 18 mm thick, double-sided melamine-coated particle board to ensure the cabinet's alignment and provide visual symmetry with the doors.

CONNECTIONS AND ACCESSORIES

The connections are made using German-made Hafele brand M68 mm diameter, 10 mm minifix metal connection mechanisms, and 832 mm plastic dowels.

Hinges: The cabinet uses six high-quality internal spring hinges, two of which have a soft-closing mechanism. These are produced by Hafele.

Feet: The cabinet has height-adjustable plastic feet, sized Q5 cm with a height of 5 cm, produced using injection molding.

Handles: The handles are made from 128 mm electrostatically painted aluminum, produced via injection molding in special molds.

USAGE AREA

The Stor Full-Covered Cabinet Group is designed for use in offices, open offices, meeting rooms, and workspaces.

DESIGNER / COLLECTION

The Stor Full-Covered Cabinet Group was designed by Z Design Team for the 2019/2020 collection.

MATERIAL LIBRARY

Zivella; you can access the wood, metal, fabric, and faux leather library using the QR code below.



Material Catalog



STOR FULL-COVERED CABINET

DIMENSIONS

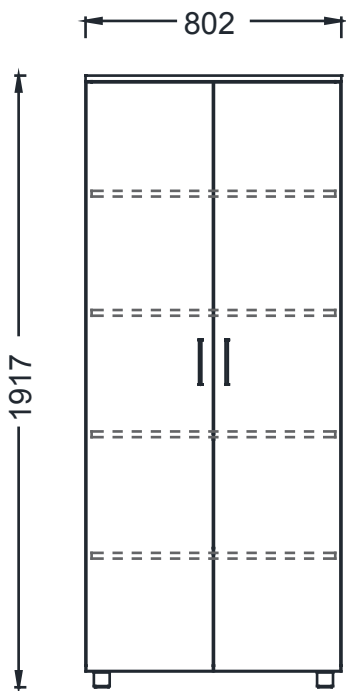

BRD80190 - STOR 80-T190

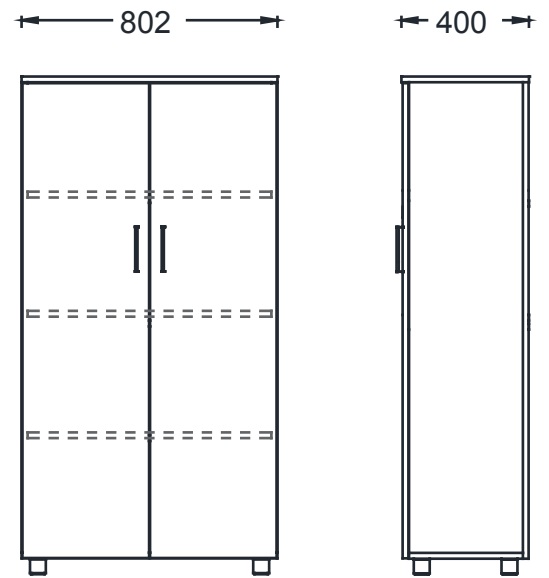
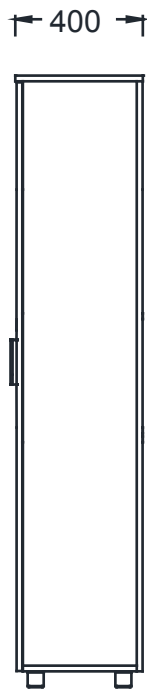

BRD80160 - STOR 80-T160

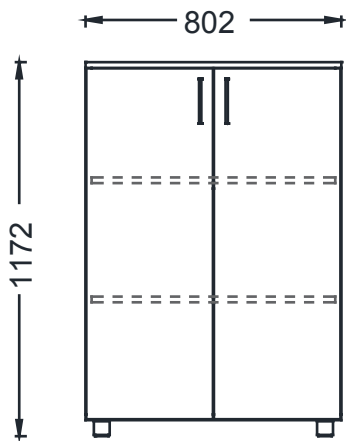

BRD80120 - STOR 80-T120

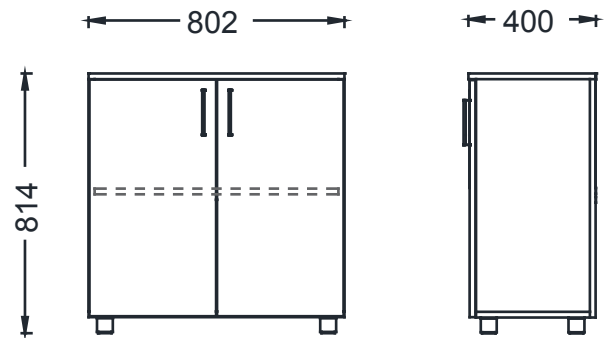

BRD8080 - STOR 80-T80

Measurements are in millimeters.